



UCG GOURMET SERIES UNDERCOUNTER

MODELS- UCG 45, UCG 65, UCG 85, UCG 105, UCG 135, UCG 165



Installation and Service Manual

UCG GOURMET SERIES UNDERCOUNTER

GENERAL INFORMATION AND INSTALLATION

A. INTRODUCTION

This manual provides the specifications and the step-by step procedures for the installation, start up, operation, cleaning, and maintenance for the Ice-O-Matic UCG Undercounter Series ice makers. **To retain the safety and performance built into this ice maker, it is important that installation and maintenance be conducted in the manner outlined in this manual.**

For more technical information, refer to www.iceomatic.com.

B. UNPACKING AND INSPECTION

1. Call your authorized Ice-O-Matic Distributor or Dealer for proper installation.
2. Visually inspect the exterior of the packaging and skid. Any severe damage noted should be reported to the delivering carrier.
3. Cut and remove the plastic strip securing the carton box to the skid. Cut open the top of the carton and remove the protection sheet. Pull out the corner posts, and then remove the carton.
4. Remove the front panel of the unit, and inspect for any concealed damage. Notify the carrier of any concealed damage.
5. Check that refrigerant lines do not rub against or touch other lines or surfaces, and the fan blade moves freely.
6. Check that the compressor fits snugly onto all its mounting pads.
7. Remove all internal support packaging and masking tape.
8. Use a clean, damp cloth to wipe the surfaces inside the storage bin and the outside of the cabinet.
9. See data plate on the rear side of the unit and check that local main voltage corresponds with the voltage specified on it.

CAUTION: Incorrect voltage supplied to the ice maker will void your parts replacement program.

10. Register the unit at www.iceomatic.com/warranty.
11. Install and adjust legs provided to level the unit.

C. LOCATION AND LEVELING

WARNING: This ice maker is designed for indoor installation only. Extended periods of operation at temperatures exceeding the following limitations will constitute misuse under the terms of the Ice-O-Matic Manufacturer's Limited Warranty, resulting in loss of warranty coverage.

1. Position the unit in the selected permanent location. Criteria for selection of location include:
 - a. Minimum room temperature of 50°F (10°C) and maximum room temperature of 100°F (40°C).

- b. Minimum water inlet temperature of 40°F (5°C) and maximum water inlet temperature of 90°F (35°C).
 - c. Well ventilated location.
 - d. Service access: adequate space must be left for all service connections through the rear of the ice maker. A minimum clearance of 6" (15cm) must be left at the sides of the unit for routing air drawn into and exhausted out of the compartment to maintain proper condensing operation.
2. Level the unit in both the left to right and front to rear directions.

D. ELECTRICAL CONNECTIONS

See data plate for current requirements to determine wire size to be used for electrical connections. All Ice-O-Matic ice makers require a solid earth wire. They are supplied from the factory completely pre-wired and require only electrical power connections to the wire cord provided at the rear of the unit. Make sure the ice maker is connected to its own circuit and individually fused (see data plate for fuse size). The maximum allowable voltage variation should not exceed -10% and +10% of the data plate rating. Low voltage can cause faulty functioning and may be responsible for serious damage to the overload switch and motor windings. Check voltage on the line and the ice maker's data plate before connecting the unit.

NOTE: All external wiring should conform to national, state, and local standards and regulations.

E. WATER SUPPLY AND DRAIN CONNECTIONS

GENERAL

When choosing the water supply for the ice maker consideration should be given to:

- a. Length of run
- b. Water clarity and purity
- c. Adequate water supply pressure

Since water is the most important single ingredient in producing ice, the three items listed above are extremely significant. Low water pressure, below 14 psi (1 bar), may cause malfunction of the ice maker. Water containing excessive minerals will tend to produce cloudy ice cubes, in addition to scale build-up on parts of the water system.

WATER SUPPLY

Connect the 3/4" male fitting of the solenoid water inlet valve, using the flexible tube supplied, to the cold-water supply line with regular plumbing fitting and a shut-off valve installed in an accessible position between the water supply line and the unit. If water contains a high level of impurities, it is advisable to consider the use of an appropriate water filter.

WATER SUPPLY - Water cooled models (UCG165)

The water cooled versions require two separate inlet water supplies, one for the water sprayed for making the ice cubes and the other for the water cooled condenser. Connect the 3/4" male fitting of the water regulating valve using the flexible hose supplied with the unit to the cold water supply line with regular plumbing fitting and a shut-off valve installed in an accessible position between the water supply line and the unit.

WATER DRAIN

The recommended drain tube is a plastic or flexible tube with 18 mm (3/4") I.D. runs to an open trapped and vented drain. When the drain is a long run, allow 3 cm pitch per meter (1/4" pitch per foot). A vertical open vent, at the unit drain connection, is also required for proper sump drainage.

WATER DRAIN - Water cooled models

The water drain line from the condenser, on water cooled versions, is internally connected with the drain fitting of the unit. It is strongly recommended therefore to install a vertical open vent on unit drain line high point to ensure good draining and to direct the drain line to a trapped and vented floor drain receptacle. This to make sure of the proper flow of the drained water as, in case of poor drainage, the water running out from the condenser may inopportunately flow, through the unit drain tubing, into the ice storage bin.

NOTE. The water supply and the water drain must be installed to conform with the local code. In some case a licensed plumber and/ or a plumbing permit is required.

F. FINAL CHECK LIST

1. Is the unit in a room where the ambient temperatures are within a minimum of 50°F (10°C) even in winter months?
2. Is there at least a 6" (15cm) clearance around the unit for proper air circulation?
3. Is the unit level? (IMPORTANT)
4. Have all the electrical and plumbing connections been made, and is the water supply shut-off valve open?
5. Has the voltage been tested and checked against the data plate rating?
6. Has the water supply pressure been checked to ensure a water pressure of at least 14 psi (1 bar)?
7. Check all refrigerant lines and conduit lines to guard against vibrations and possible failure.
8. Have the bolts holding the compressor down been checked to ensure that the compressor is snugly fitted onto the mounting pads?
9. Have the bin liner and cabinet been wiped clean?
10. Has the owner/user been given the Installation and Service Manual and been instructed on the importance of periodic maintenance checks?
11. Has the unit been registered for warranty? Check for correct model and serial number against the serial plate.

12. Has the owner been given the name and the phone number of the authorized Ice-O-Matic Service Agency serving him/her?

G. INSTALLATION PRACTICE

WARNING: This icemaker is not designed for outdoor installation and will not function in ambient temperatures below 50°F (10°C) and above 100°F (40°C). This ice maker will malfunction with water temperatures below 40°F (5°C) or above 90°F (35°C).

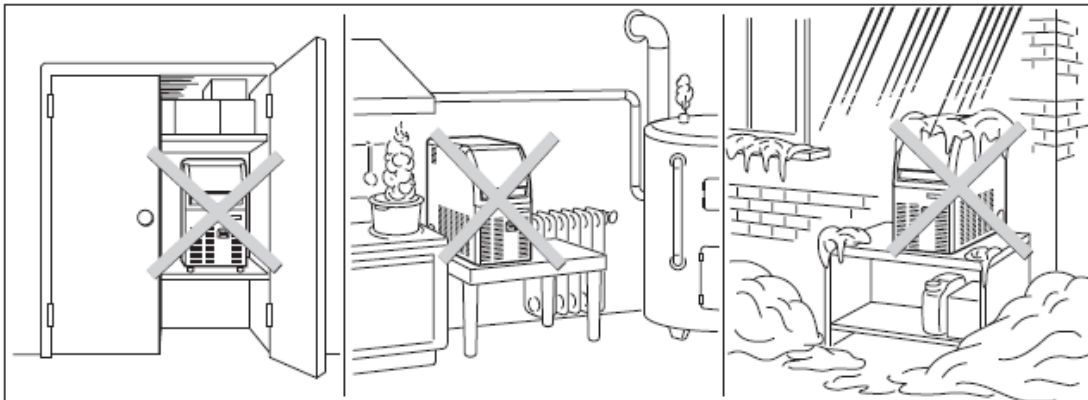

H. OPERATING INSTRUCTIONS

START UP

After having correctly installed the ice maker and completed the plumbing and electrical connections, perform the following “start-up” procedure.

UCG45/65/85/105

A -Remove the unit front panel and locate the cleaning switch on the control box.

B- Set the cleaning switch in the cleaning position (II). This will close the electrical circuit to the water inlet valve and to the hot gas valve.

C- Switch ON the power line disconnect switch. Unit will start up in water filling phase mode. During this phase the components energized are:

WATER INLET SOLENOID VALVE

HOT GAS SOLENOID VALVE

The Water pump and the Fan motor are also in operation.

D- Let unit stay in water filling phase mode for about three/four minutes till water is coming out from the drain hose, then move the cleaning switch to the operation position (I).

UCG135/165

E- Give power to the unit to start it up by switching ON the power line main switch; the unit will start automatically in defrost cycle with the following components energized:

WATER INLET SOLENOID

VALVE HOT GAS VALVE

COMPRESSOR

ELECTRONIC TIMER

NOTE. During the defrost cycle, the water inlet solenoid valve is energized. The water flows through the valve to the back side of the evaporator platen and then down to fill up the icemaker sump tank for the next freezing cycle.

OPERATIONAL CHECKS

A. The unit now starts its first freezing cycle with the following components in operation:

COMPRESSOR

WATER PUMP

FAN MOTOR in air cooled version

B. Check to see through the ice discharge opening that the spray system is correctly seated and that the water jets uniformly reach the interior of the inverted cup molds; also make sure that the plastic curtain is hanging freely and there is not excessive water spilling through it.

C. The ice making process takes place thereby, with the water sprayed into the molds that gets gradually refrigerated by the heat exchanged with the refrigerant flowing into the evaporator serpentine.

D. On units UCG45/65/85/105 when the evaporator temperature reaches a preset value the evaporator thermostat or cube size control changes its contacts; the freezing cycle ends and starts the defrost or harvest cycle.

E. On models UCG 135/165 freezing cycle is completed through an electronic timer energized by the evaporator thermostat. It starts when the cube size thermostat/control bulb (pig tail) located on the evaporator serpentine reaches a temperature of approx. -15°C (5°F).

On units UCG135/165 the additional Time (12') of the freezing cycle starts when the cube size thermostat control bulb (pig tail) located on the evaporator coil reaches a temperature of approx. -15°C. Freezing time will range between 20 and 22 minutes in a 21 °C ambient temperature, longer if above this temperature and shorter if below. Then the unit goes directly into the Defrost Cycle. The average complete cycle time is between 23 and 25 minutes.

F Check, during the first defrost/harvest cycle, that the incoming water flows correctly into the sump reservoir in order to re-fill it and the surplus overflows through the overflow drain tube.

- G** Check the texture of ice cubes just released. Right size must have a small depression (about 5-6 mm) in their crown. If not, wait for the second defrost/harv before performing any adjustment.

- H** If required on model UCG 45/65/85/105, the length of the freezing cycle can be modified by turning the knob of the cube size control or evaporator thermostat located in front of the machine until the desired size is achieved.

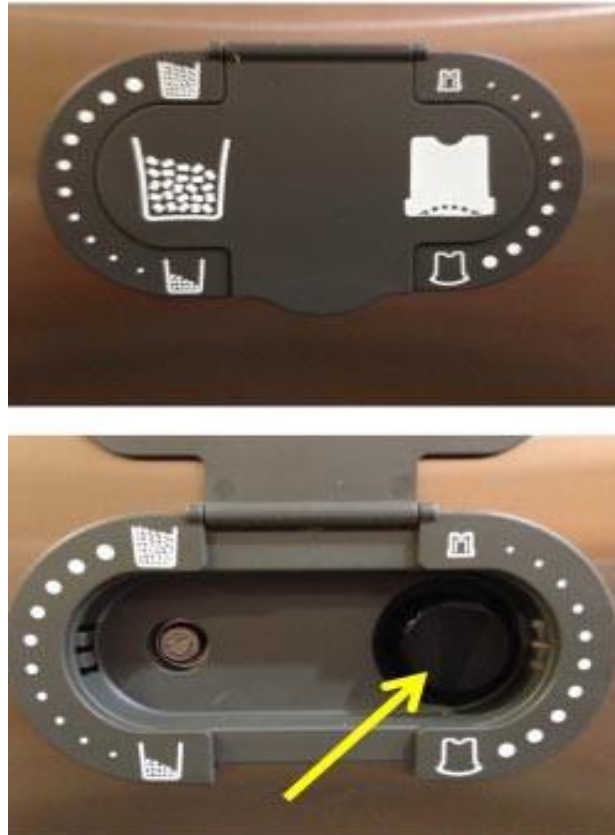

if the temperature of the room in which the machine is placed is below 20°C, the cubes will tend to be partly hollowed out (see fig. on right).

If, on the other hand, the room temperature is above 30°C the cubes produced will have a jagged rim of ice around the crown.

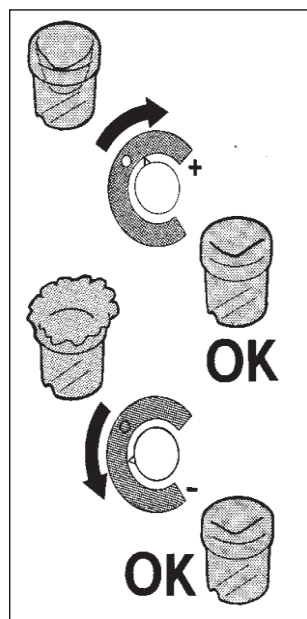

If it is thought necessary, the above situations can be rectified by, in the first case, turning the control knob (as little or as much as is required) clockwise and, in the second case, turning the knob to the right counterclockwise.

It should, however, be remembered that if the room temperature returns later to the 20÷ 30°C range, the knob indicator must once again be turned to the previous position.

If the ice cubes are shallow and cloudy, it is possible that the ice maker runs short of water during the end of the freezing cycle or, the quality of the supplied water requires the use of an appropriate water filter or conditioner.

- I At the end of the defrost or harvest cycle hold a handful of ice cubes against the bulb of the storage bin thermostat; the icemaker switch OFF in about one-two minutes. Take out the ice from the storage bin thermostat. The ice maker should restart automatically in three-four minutes.

NOTE. *The bin thermostat is factory set at 1°C (35°F) OUT and 4°C (39°F) IN.*

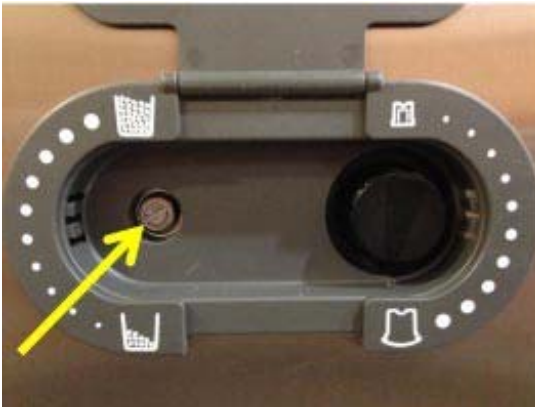

- J Re-fit the unit front panel then instruct the owner/user on the general operation of the ice machine and about the cleaning and care it requires

PRINCIPLE OF OPERATION

In the Ice-O-Matic cube ice makers, the water used to make the ice is kept constantly in circulation by an electric water pump which primes it to the spray system nozzles form where it is diverted into the inverted mold cups of the evaporator. A small quantity of the sprayed water freezes into ice; the rest of it cascades by gravity into the sump assembly below for recirculation.

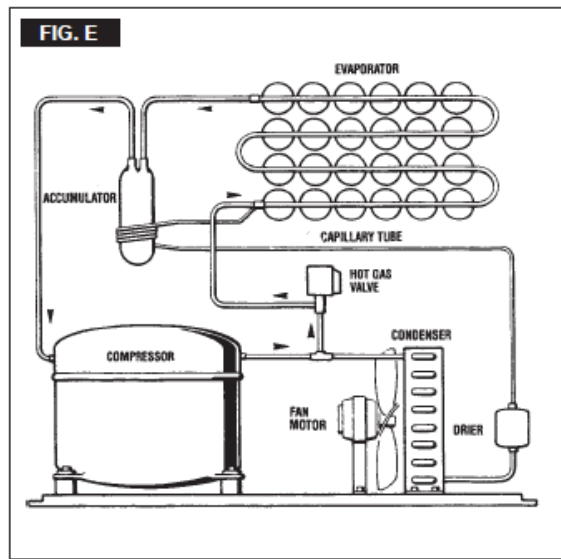
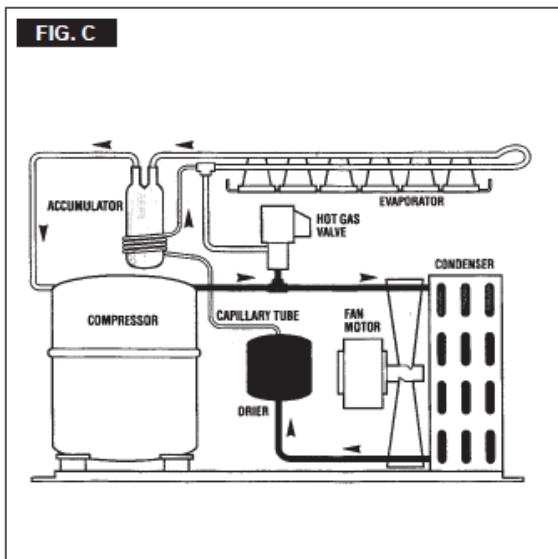
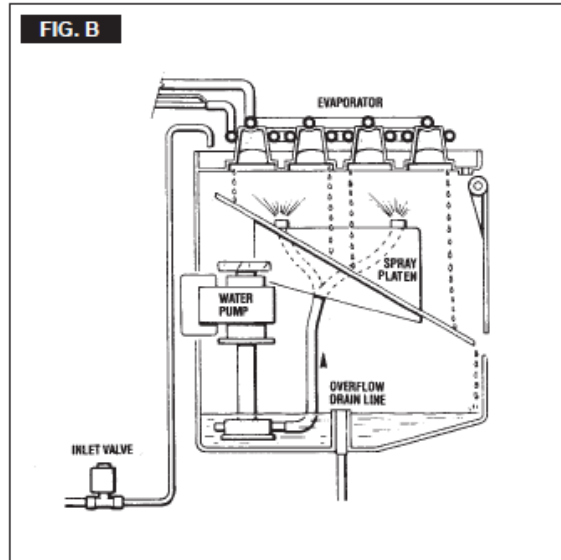
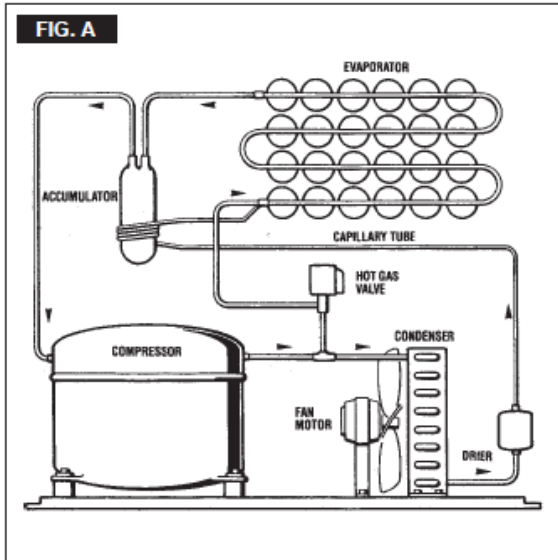

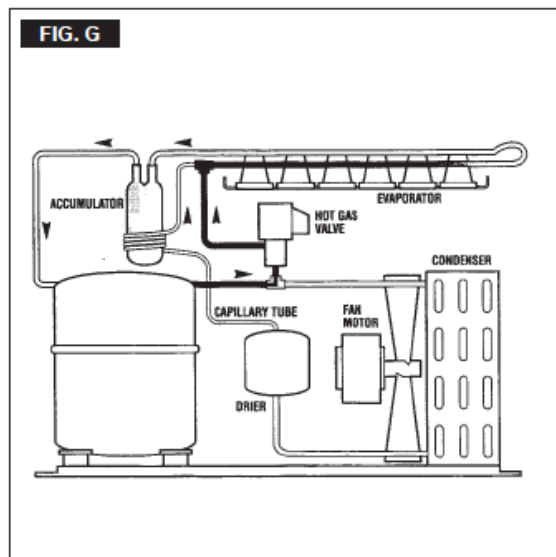
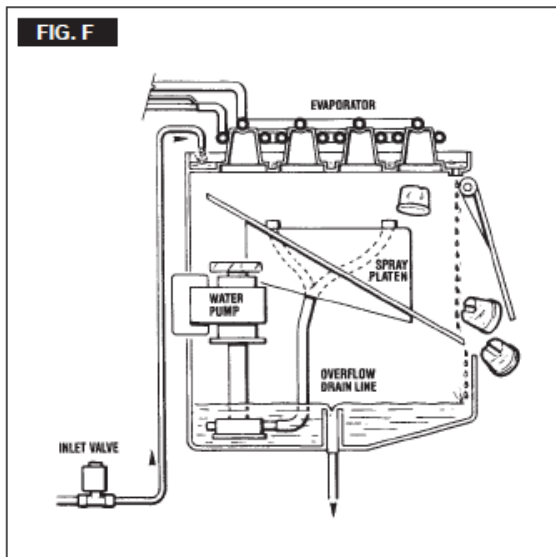

FREEZING CYCLE

The hot gas refrigerant discharged out from the compressor reaches the condenser where, being cooled down, condenses into liquid. Flowing into the liquid line it passes through the drier/filter, then it goes all the way through the capillary tube where it loses its pressure. Next the refrigerant enters into the evaporator serpentine (which has a larger diameter than the capillary tube) and starts to boil off; this reaction is emphasized by the heat transferred by the sprayed water. The refrigerant then increases in volume and changes entirely into vapor.

The vapor refrigerant then passes through the suction accumulator (used to prevent that any small amount of liquid refrigerant may reach the compressor) and through the suction line. In both the accumulator and the suction line it exchanges heat with the refrigerant flowing into the capillary tube (warmer), before to be sucked in the compressor and to be recirculated as hot compressed refrigerant gas.

The freezing cycle on UCG45/45/65/85/105 is controlled by only the evaporator thermostat which has its bulb in contact with the evaporator serpentine while in UCG135/165 there is a second phase controlled by a timer.

The electrical components in operation during the freezing cycle are:

COMPRESSOR

WATER PUMP

FAN MOTOR (in air cooled version)

On UCG45/65/85 air cooled versions the refrigerant head pressure is gradually reduced from a value of approx. **11 bars (155 psig)** at the beginning of the freezing cycle with the unit at 21°C (70°F) ambient temperature, to a minimum value of approx. **7 bars (100 psig)** just at the end of the freezing cycle few seconds before the starting of the defrost cycle.

On UCG105/135/165 air cooled versions the refrigerant head pressure is kept between two pre-set values (**10÷8,5 bar - 140÷120 psig**) with the unit a 21°C (70°F) ambient temperature. The declining of the pressure is relied to the reduction of the evaporating pressure, caused by the progressive growth of the ice thickness into the inverted cup molds and to the flow of air drawn through the air cooled condenser by the fan motor. The above values are in relation as well to the ambient temperature of the ice maker site and they are subject to rise with the increase of this temperature.

On UCG45/65/85/105/135 water cooled versions the refrigerant head pressure ranges between **8.5 and 10 bars (120÷140 psig)** being controlled by an automatic hi pressure control that energizes a water solenoid valve located on the water line to the condenser, which rates the cooling water to the condenser. On UCG165 water cooled versions the head pressure is constant at **9.5 bar (135 psig)** controlled by a water regulating valve.

At starting of freezing cycle the refrigerant suction or lo-pressure lowers rapidly to **1.0 bar - 14 psig** then it declines gradually - in relation with the growing of the ice thickness - to reach, at the end of the cycle, approx. **0÷0.1 bar - 0÷1.5 psig** on the models UCG45/65/85 and 0.85 and 0.2 ÷0.3 bar (3÷4 psig) on models UCG105/135/165 with the cubes fully formed in the cup molds. The total length of the freezing cycle ranges from 23 to 25 minutes.

DEFROST OR HARVEST CYCLE

On UCG45/65/85/105 the temperature of the evaporator thermostat, in contact with the evaporator serpentine, drops to a pre-set value it changes its electrical contacts energizing the herebelow shown components. On UCG135/165 when the timer changes its electrical contacts energizing the same components).

COMPRESSOR

WATER INLET SOLENOID

VALVE HOT GAS SOLENOID VALVE

The incoming water, passing through the water inlet valve and the flow control, runs over the evaporator platen and then flows by gravity through the dribbler holes down into the sump/ reservoir.

The water filling the sump/reservoir forces part of the surplus water from the previous freezing cycle to go out to the waste through the overflow pipe. This overflow limits the level of the sump water which will be used to produce the next batch of ice cubes

Meanwhile the refrigerant, as hot gas discharged from the compressor, flows through the hot gas valve directly into the evaporator serpentine by- passing the condenser.

The hot gas circulating into the serpentine of the evaporator warms up the copper molds causing the harvest of the ice cubes. The ice cubes, released from the cups, drop by gravity onto a slanted cube chute, then through a curtained opening they fall into the storage bin.

On UCG45/65/85/105 when the temperature of the evaporator thermostat bulb reaches the value of $+3 \pm 4^{\circ}\text{C}$ their electrical contacts move back to the previous position activating a new freezing cycle and deenergizing both the hot gas and the water inlet valves (closed). On UCG135/165 as soon as the timer completes the bottom part of the cam and it is pushed again, it activates a new freezing cycle deenergizing both the hot gas and the water inlet valves (closed).

NOTE. On models UCG45,65,85 and 105 the length of the defrost/harvest cycle (not adjustable) changes according to the ambient temperature (shorter for hi ambient temperature and longer for low one).

COMPONENTS DESCRIPTION

WATER PUMP

The water pump operates continually throughout the freezing cycle. The pump primes the water from the sump to the spray system and through the spray nozzles sprays it into the inverted cup molds to be frozen into crystal clear ice cubes.

WATER INLET SOLENOID VALVE - 3/4 MALE FITTING

The water inlet solenoid valve is energized only during the defrost cycle. When energized it allows a metered amount of incoming water to flow over the evaporator cavity to assist the hot gas in defrosting the ice cubes. The water running over the evaporator cavity drops by gravity, through the dribbler holes of the platen, into the sump reservoir. On UCG45/65/85/105/135 water cooled versions the water inlet solenoid valve has one inlet and two outlets with two separate solenoids energized the first (ice production) by the contacts 3-2 of the evaporator thermostat and the second (water cooled condenser) by a specific hi pressure control.

HOT GAS SOLENOID VALVE

The hot gas solenoid valve consists basically in two parts: the valve body and the valve coil. During the defrost cycle the hot gas valve coil is activated so to attract the hot gas valve piston in order to give way to the hot gas discharged from compressor to flow directly into the evaporator serpentine to defrost the formed ice cubes.

BIN THERMOSTAT

The bin thermostat control body is located in the front of control box behind the front panel. The thermostat sensing tube is located into a bulb holder on the side wall of the ice storage bin where it automatically shuts the icemaker OFF when in contact with the ice and re-starts the icemaker when the ice is removed. Factory settings are 1°C (35°F) OUT and 4°C (39°F) IN.

CUBE SIZE CONTROL (EVAPORATOR THERMOSTAT)

The cube size control (evaporator thermostat) body is located in the control box behind the front panel; it's basically a reverse acting temperature control which closes the contacts 3-2 when its temperature decreases and closes the opposite contacts 3-4 when the temperature rises.

The thermostat sensing bulb is located into a plastic tube (bulb holder) secured by two clips directly to the evaporator serpentine. This control determines the length of the freezing cycle and correspondingly

the size of the cubes. A lower setting will produce a larger cube (oversize) while a higher setting a smaller cube (shallow size). When closed on contacts 3-2 it activates the defrost or harvest cycle components. The cube size control is set up in the factory (knob in the black dot position) and doesn't require any adjustment when the ambient temperature remains between 20 and 30 °C (70 and 90°F).

UCG 135 – 165

The evaporator thermostat with its sensing bulb intimately in contact with the refrigerant outlet tube from the evaporator senses the evaporating refrigerant temperature (which declines in the course of the freezing cycle) and when this one reaches the pre-set value, it switches its contacts from 3-4 to 3-2 to activate the finishing cycle (2nd phase) which has a pre-set extension determined by the large diameter lobe of the timer.

FAN MOTOR (Air cooled version)

The fan motor on UCG45/65/85/105 is electrically connected in parallel to the water pump and it operates continuously only during the freezing cycle keeping the proper head pressure circulating air through the condenser fins. On UCG135/165 the operation of fan motor is controlled by a fan pressure control adjusted at preset values.

COMPRESSOR

The hermetic compressor is the heart of the refrigerant system and it is used to circulate and retrieve the refrigerant throughout the entire system. It compresses the low pressure refrigerant vapor causing its temperature to rise and become high pressure hot vapor (hot gas) which is then released through the discharge valve.

WATER SPRAY SYSTEM

Through its nozzles it sprays the water in each individual cup to be frozen into ice.

SAFETY HI TEMPERATURE THERMOSTAT

Located in the control box it is a manual reset switch that trips OFF the operation of the machine when its bulb (located on the liquid line just before the drier) reaches the temperature of 70°C (158°F).

CLEANING SWITCH (UCG45/65/85/105)

Located on the bottom left side of the control box is used to energize the water inlet and the hot gas valves so to charge the water into the sump tank of the machine.

HI PRESSURE CONTROL (Water cooled version)

Used only on UCG45/65/85/105/135 water cooled versions it operates to keep between two preset values the hi-side or discharge pressure of the refrigerant system by energizing the coil of the water inlet solenoid valve that control the cooling water flow to the condenser.

ELECTRONIC TIMER (UCG135-165)

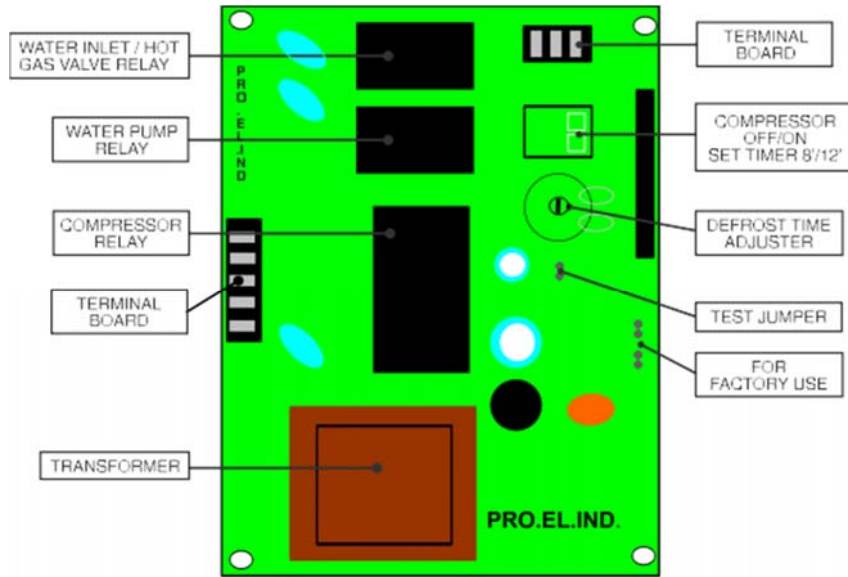

Equipped with a Two Keys Dip Switch and one Potentiometer, it manage the length of second fase of the freezing cycle and the entire defrost/ harvest cycle with a factory pre-set times .The first key (1) replaces the “Compressor Switch” used on the previous electro-mechanical version; factory setting is ON position to energize the compressor during the standard operation of the ice machine. The same key (1) is switched to OFF position when the cleaning cycle is required keeping the water pump only in operation. The second key (2) allows the setting of the timed portion (Ta) of the freezing cycle according to the model of the ice machine.

Dip Switch factory setting combinations

	N. 1	N. 2
UCG 135/165	ON	ON

Resuming Chart with Keys 1 & 2 functions

	N. 1	N. 2
ON	Standard Setting Compressor ON	Ta = 12'
OFF	Cleaning Mode Compressor OFF	Ta = 8'

UCG GOURMET SERIES UNDERCOUNTER

The potentiometer is used to adjust the defrost time and it is set directly from the factory according to the model of the ice machine. It can be adjustable from a minimum defrost time of 60" (turn clockwise), to a maximum of 180" (turn counterclockwise).

MASTER SWITCH (only UCG45/65/85/105)

Fitted in the control box the master switch has to be used to start-up and to stop the ice maker operation.

COMPRESSOR SWITCH (only UCG135/165)

Located in the control box is used to de-energized the compressor during the cleaning.

FAN PRESSURE CONTROL (only UCG135-135)

Used on air cooled ice makers to maintain the head pressure within the preset values.

WATER REGULATING VALVE (only UCG165Water cooled version only)

This valve controls the head pressure in the refrigerant system by regulating the flow of water going to the condenser. As pressure increases, the water regulating valve opens to increase the flow of cooling water.

UNIT REFRIGERANT CHARGES

The UCG Undercounter Series contains R134A refrigerant. See table below for specifics by model.

Model	Electrical (volts/Hz/phase)	Fuse Size (Amp)	Amps (Unit RLA)	Refrigerant Charge R134A
UCG 45 A	230/50/1	10	2.2	250 gr – 8.82 oz
UCG 45 W	230/50/1	10	2.2	250 gr – 8.82 oz
UCG 65 A	230/50/1	10	2.4	260 gr – 9.17 oz
UCG 65 W	230/50/1	10	2.4	250 gr – 8.82 oz
UCG 85 A	230/50/1	10	3.2	290 gr – 10.2 oz
UCG 85 W	230/50/1	10	3.2	250 gr – 8.82 oz
UCG 105 A	230/50/1	10	3.5	320 gr – 11.3 oz
UCG 105 W	230/50/1	10	3.5	250 gr – 8.82 oz
UCG 135 A	230/50/1	10	3.8	330 gr – 11.6 oz
UCG 135 W	230/50/1	10	3.8	300 gr – 10.6 oz
UCG 135 A	230/50/1	10	5.3	320 gr – 11.3 oz
UCG 135W	230/50/1	10	5.3	330 gr – 11.6 oz

SERVICE DIAGNOSIS

SYMPTOM	POSSIBLE CAUSE	SUGGESTED CORRECTION
Unit will not run	Main switch in OFF position Safety device intervention (thermostat - pressure switch) Loose electrical connections Inoperative bin thermostat	Turn switch to ON position Eliminate the stop motivation and push the reset button or replace. Check wiring Replace thermostat
Compressor cycles intermittently	Low voltage Contactor with burnt contacts Non-condensable gas in system Compressor starting device with loose wires Too high room temperature	Check circuit for overloading Check voltage at the supply to the building. If low, contact the power company Clean or replace Purge the system Check for loose wires in starting device Move the unit in a more suitable place
Cubes too small	Freezing cycle too short Capillary tube partially restricted Moisture in the system Shortage of water Shortage of refrigerant Inoperative evaporator thermostat	Review setting of DIP SWITCH keys Blow charge, add new gas & drier, after evacuating system with vacuum pump Same as above See remedies for shortage of water Check for leaks & recharge Replace thermostat
Cloudy cubes	Shortage of water Dirty water supply Accumulated impurities cleaner Water pump losing discharge pressure	See remedies for shortage of water Use water softener or water filter Use Cleaner Ice Machine Check bearings. Replace.
Shortage of water	Water spilling out through curtain Water solenoid valve not opening Water leak in sump area Water flow control plugged	Check or replace curtain Replace valve Locate and repair Remove and clean

SERVICE DIAGNOSIS

SYMPTOM	POSSIBLE CAUSE	SUGGESTED CORRECTION
Irregular cubes size & some cloudy	Some jets plugged Shortage of water Unit not level	Remove jet cover and clean See shortage of water Level as required
Cubes too large	Freezing cycle too long Inoperative evaporator thermostat	Adjust evap. thermostat Replace thermostat
Decreased ice capacity	Inefficient compressor Leaky water valve Non-condensable gas in system Poor air circulation or excessive hot location Overcharge of refrigerant Capillary tube partially restricted Hot gas solenoid valve leaking Undercharge of refrigerant Discharge head pressure too high	Replace Repair or replace Purge the system Relocate the unit or provide for more ventilation Correct the charge. Purge off slowly Blow charge, add new gas & drier, after evacuating system with vacuu pump Replace valve Charge to data plate indication See incorrect discharge pressure
Poor harvest	Restriction in incoming water line Water inlet valve not opening Hot gas valve orifice restricted Discharge head pressure too low	Check water valve strainer and flow control. If necessary enlarge the flow control orifice Valve coil with open winding Replace valve Replace hot gas valve assy See incorrect discharge pressure
Incorrect discharge pressure	Inoperative fan pressure control Inoperative fan motor Water regulating valve misadjusted	Replace pressostat Replace Adjust its setting stem
Excessive water in unit base	Water tubing leaking	Check. Tighten or replace

CLEANING

Ice-O-Matic recommends cleaning the ice machine every 6 months, but not more than once per month to avoid potential damage to the machine.

WARNING: Before proceeding with any cleaning and maintenance operation, make sure the power is disconnected and water supply is turned off.

ADJUSTMENT PROCEDURES

A. ADJUSTMENT OF THE CUBE SIZE

NOTE: Before performing actual adjustment of the cube size, check other possible causes for cube size problems, refer to the Service Diagnosis Section for problem review and analysis. Do not perform any adjustment until the ice making system has progressed through several complete freeze and harvest cycles in order to observe the size and quality of ice cubes and whether or not the cube size problem exists.

if the temperature of the room in which the machine is place is below 20°C, the cubes will tend to be partly hollowed out (see fig. on right).

If, on the other hand, the room temperature is above 30°C the cubes produced will have a jagged rim of ice around the crown.

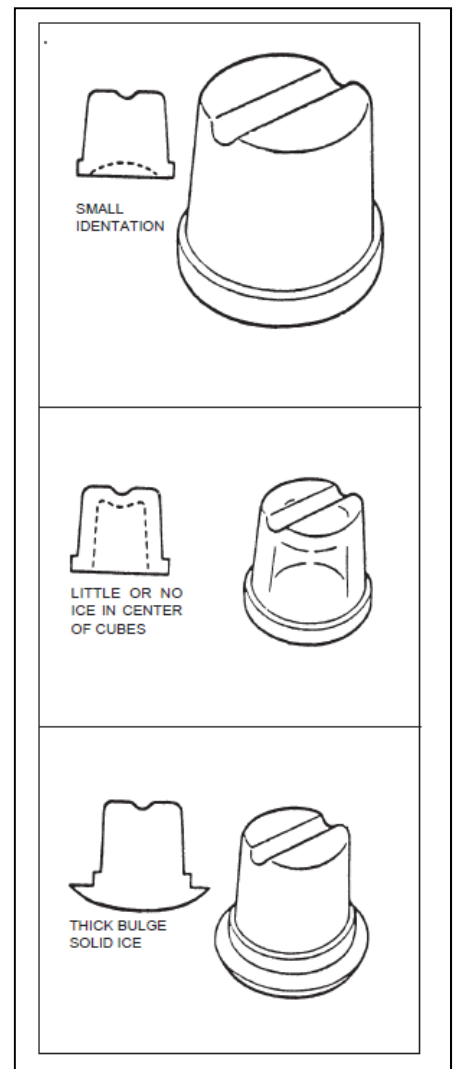

UCG 45-65-85-105

WIRING DIAGRAM

AIR & WATER COOLED

230/50-60/1



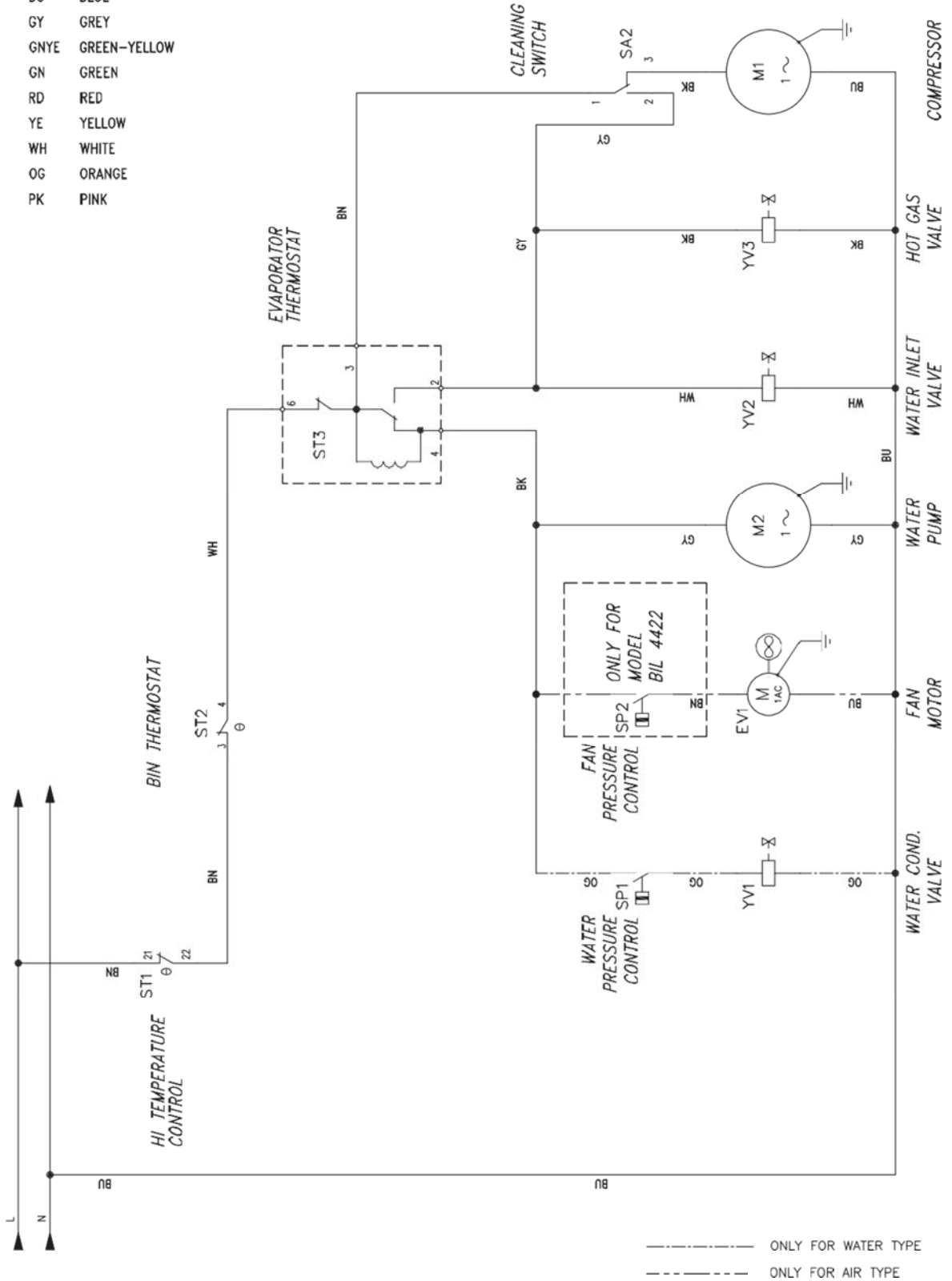





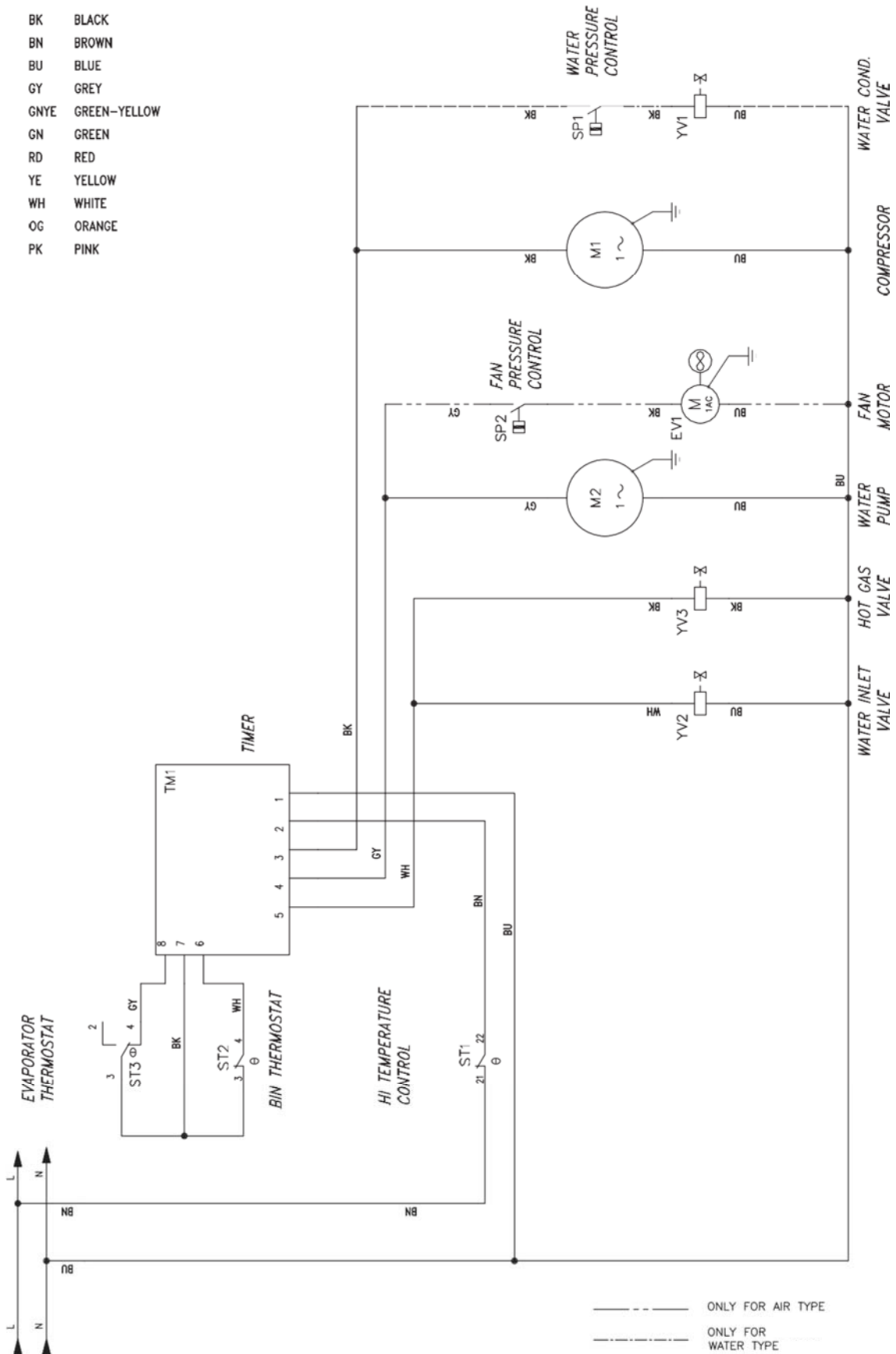







- BK BLACK
- BN BROWN
- BU BLUE
- GY GREY
- GNYE GREEN-YELLOW
- GN GREEN
- RD RED
- YE YELLOW
- WH WHITE
- OG ORANGE
- PK PINK



UCG 135-165
WIRING DIAGRAM
ELECTRONIC TIMER VERSION
230/50-60/1

- BK BLACK
- BN BROWN
- BU BLUE
- GY GREY
- GNYE GREEN-YELLOW
- GN GREEN
- RD RED
- YE YELLOW
- WH WHITE
- OG ORANGE
- PK PINK



Sim.\Sym.	Sigla \Item	Funzione \Use Type	Sim.\Sym.	Sigla \Item	Funzione \Use Type	Sim.\Sym.	Sigla \Item	Funzione \Use Type
	EV1	Fan motor Ventilatore		TM1	Electronic timer Timer elettronico			
	M1	Compressor Compressore		WS1	Water level sensor Sensore livello acqua			
	M2	Water pump Pompa acqua		YV1	Water condenser valve Elettrovalvola condensatore acqua			
	M3	Pump water discharge Pompa scarico acqua		YV2	Water inlet valve Elettrovalvola ingresso acqua			
	SA2	Power switch Interruttore generale		YV3	Hot gas valve Elettrovalvola gas caldo			
	SK1	PWC control board Scheda controllo PWC						
	SP1	Pressure water control Pressostato acqua						
	SP2	Fan pressure control Pressostato ventilatore						
	ST1	HI Temperature control Controllo alta temperatura						
	ST2	Bin thermostat Termostato magazzino						
	ST3	Evaporator thermostat Termostato evaporatore						

WARRANTY

Please visit www.iceomatic.com/warranty to register your unit and to get current warranty information. Refer to it for applicable coverage. In general warranty covers defects in material or workmanship. It does not cover maintenance, corrections to installations, or situations when the machine is operated in circumstances that exceed the limitations printed in this manual.